

Converting Equipment

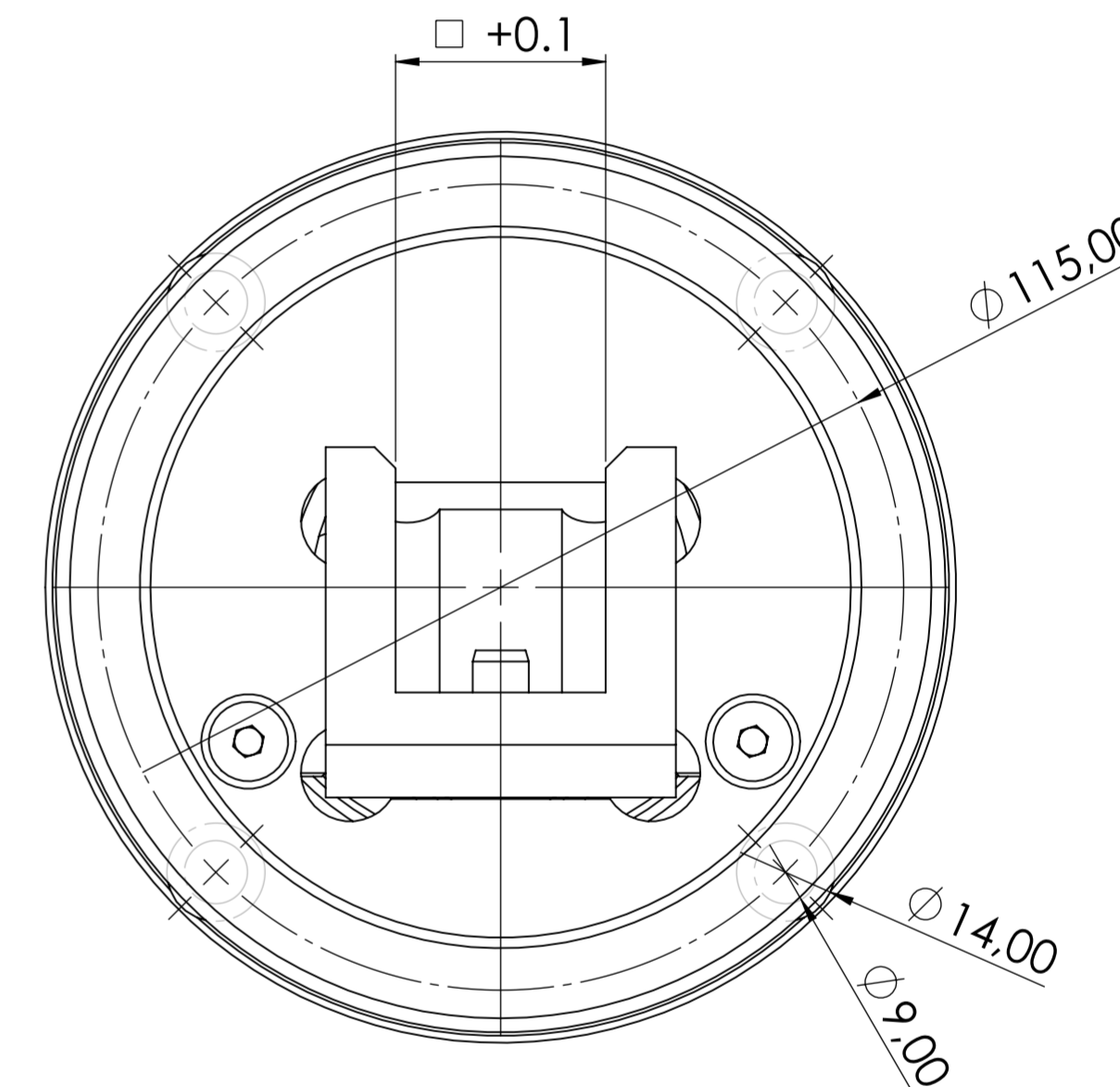
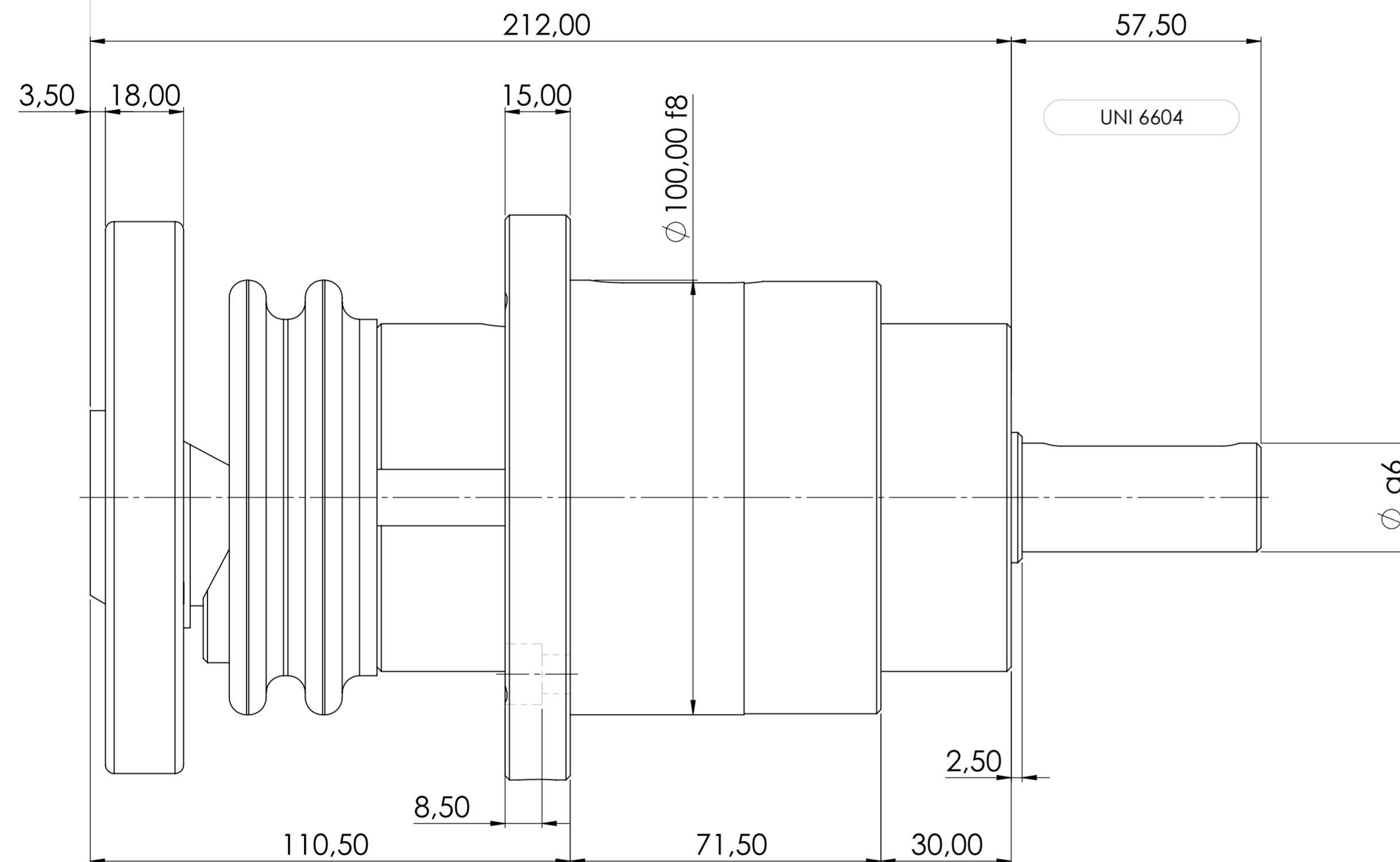

TIPO / TYPE: 12-LF-1-Q19÷30U-C50	PORTATA MAX / MAX LOAD: 2920 N - 5840 N	VELOCITA' MAX / MAX SPEED: 300 RPM	A RICHIESTA / ON REQUEST:
	QUADRI STANDARD / SQUARE STANDARD SOCKET: <input type="checkbox"/> 25 - <input type="checkbox"/> 30	ØALBERINO STANDARD / STANDARD SHAFT DIAMETER: Ø25 - Ø30	QUADRO/ SQUARE SOCKET: _____ mm
Compatibile con: SL50			